



Cim-Tek® Filtration

Bio-Tek®



Renewable Fuels Technology

**NEW SIZES
AVAILABLE**





Alcohol Monitors

High Performance / High-Flow / Long Life





Application

-  Detects phase separation in Ethanol-blended gasolines up to E15 & reduces the fuel flow which indicates phase separation
-  High performance particulate removal
-  Designed for gasoline service station pumps, commercial fueling dispensers, most Dresser®, Tokheim®, and Gilbarco® service station dispensers

Design Features

-  25 gpm (94.6 lpm) maximum flow
-  50 psi (3.4 bar) maximum working pressure
-  High performance microglass media designed for ethanol-blended fuels up to E15
-  5 micron, 10 micron, and 30 micron filtration media available

Benefits

-  Filters high levels of contaminants while monitoring for phase separation
-  High-flow...25gpm...Perfect for split systems feeding two hoses
-  More than twice the life compared to filters using cellulose media
-  Recognized by Underwriters Laboratories (UL®) for use in service station pumps and dispensers
-  Pre-lubed gaskets included...Easy to install



Bio-Tek® Monitor Filters Dimensional Information

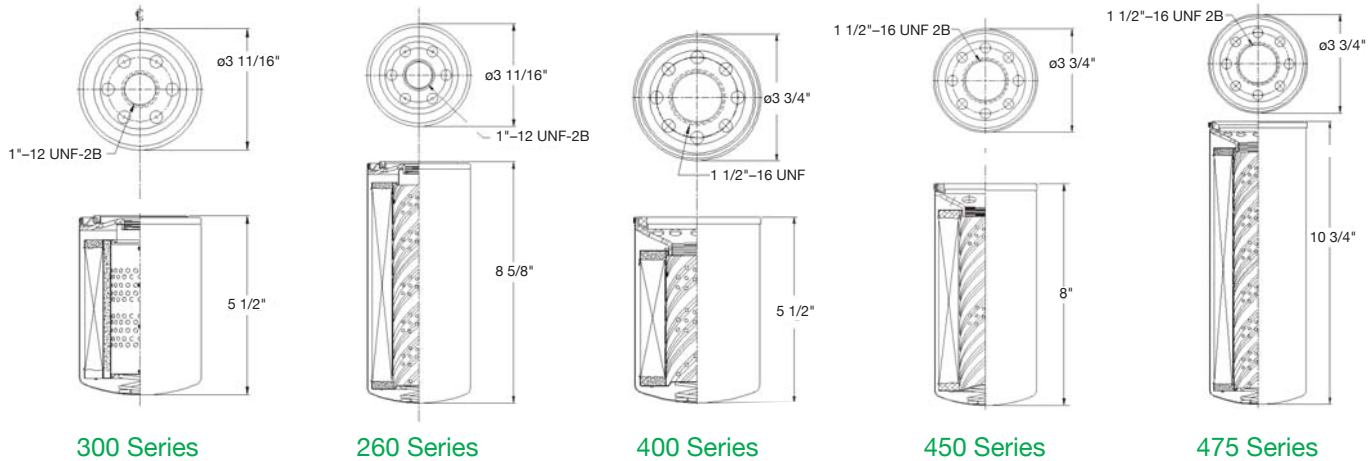

300 Series

260 Series

400 Series

450 Series

475 Series

Bio-Tek® Alcohol Monitor Filter (Detects Phase Separation in Ethanol Blends up to E15)

| Part No. | Model No. | Description | Pressure | Flow | Thread Size |
|----------|------------|--|------------------|-------------------|---------------|
| 70116 | 300MB-05 | 5 Micron Phase Separation Monitor & Particulate Filter | 50 PSI / 3.4 Bar | 25 Gpm / 94.6 Lpm | 1"–12 UNF |
| 70122 | 300MB-10 | 10 Micron Phase Separation Monitor & Particulate Filter | 50 PSI / 3.4 Bar | 25 Gpm / 94.6 Lpm | 1"–12 UNF |
| 70018 | 300MB-30 | 30 Micron Phase Separation Monitor & Particulate Filter | 50 PSI / 3.4 Bar | 25 Gpm / 94.6 Lpm | 1"–12 UNF |
| 70117 ★ | 260MB-10 | 10 Micron High Capacity Phase Separation Monitor & Particulate Filter | 50 PSI / 3.4 Bar | 25 Gpm / 94.6 Lpm | 1"–12 UNF |
| 70114 | 400MB-05 | 5 Micron Phase Separation Monitor & Particulate Filter | 50 PSI / 3.4 Bar | 25 Gpm / 94.6 Lpm | 1 1/2"–16 UNF |
| 70120 | 400MB-10 | 10 Micron Phase Separation Monitor & Particulate Filter | 50 PSI / 3.4 Bar | 25 Gpm / 94.6 Lpm | 1 1/2"–16 UNF |
| 70106 | 400MB-30 | 30 Micron Phase Separation Monitor & Particulate Filter | 50 PSI / 3.4 Bar | 25 Gpm / 94.6 Lpm | 1 1/2"–16 UNF |
| 70023 ★ | 450MB-10 | 10 Micron High Capacity Phase Separation Monitor & Particulate Filter | 50 PSI / 3.4 Bar | 25 Gpm / 94.6 Lpm | 1 1/2"–16 UNF |
| 70111 ★ | 475XLMB-10 | 10 Micron Extended Life Phase Separation Monitor & Particulate Filter | 50 PSI / 3.4 Bar | 25 Gpm / 94.6 Lpm | 1 1/2"–16 UNF |

Bio-Tek® Alcohol Monitor Filter Adaptors

| Part No. | Material | Description | Fuel Ports | Nose | Use With |
|----------|-----------|----------------|------------|---------------|----------------------|
| 50003 | Cast-Iron | Single Adaptor | 3/4" NPT | 1"–12 UNF | 260, 300 Series |
| 50181 | Aluminum | Single Adaptor | 3/4" NPT | 1"–12 UNF | 260, 300 Series |
| 50002 | Cast-Iron | Single Adaptor | 1" NPT | 1"–12 UNF | 260, 300 Series |
| 50005 | Cast-Iron | Single Adaptor | 1 1/2" NPT | 1"–12 UNF | 260, 300 Series |
| 50006 | Aluminum | Double Adaptor | 1 1/2" NPT | 1"–12 UNF | 260, 300 Series |
| 50015 | Cast-Iron | Single Adaptor | 1 1/2" NPT | 1"–12 UNF | 260, 300 Series |
| 50032 | Aluminum | Single Adaptor | 1" NPT | 1 1/2"–16 UNF | 400, 450, 475 Series |

NOTE: See adaptor page for additional details.

Bio-Tek® Alcohol Monitor Replacement Gaskets

| Part No. | Description |
|----------|--|
| 90025 | Buna-N Pre-Lubed Gasket Used On 260 and 300 series |
| 90036 | Buna-N Pre-Lubed Gasket Used On 400 series |

* Filters are not to be used with aviation applications.

REVISION B 08/07

★ New model

CENTRAL ILLINOIS MANUFACTURING COMPANY

201 NORTH CHAMPAIGN STREET • BEMENT, ILLINOIS 61813 • TOLL FREE PHONE: 888-898-7187 • TOLL FREE FAX: 888-515-2611
PHONE: 217-678-2511 • FAX: 217-678-2611 • INFO@CIM-TEK.COM • WWW.CIM-TEK.COM